

DIMENSIONS

QUADSTAR 1065

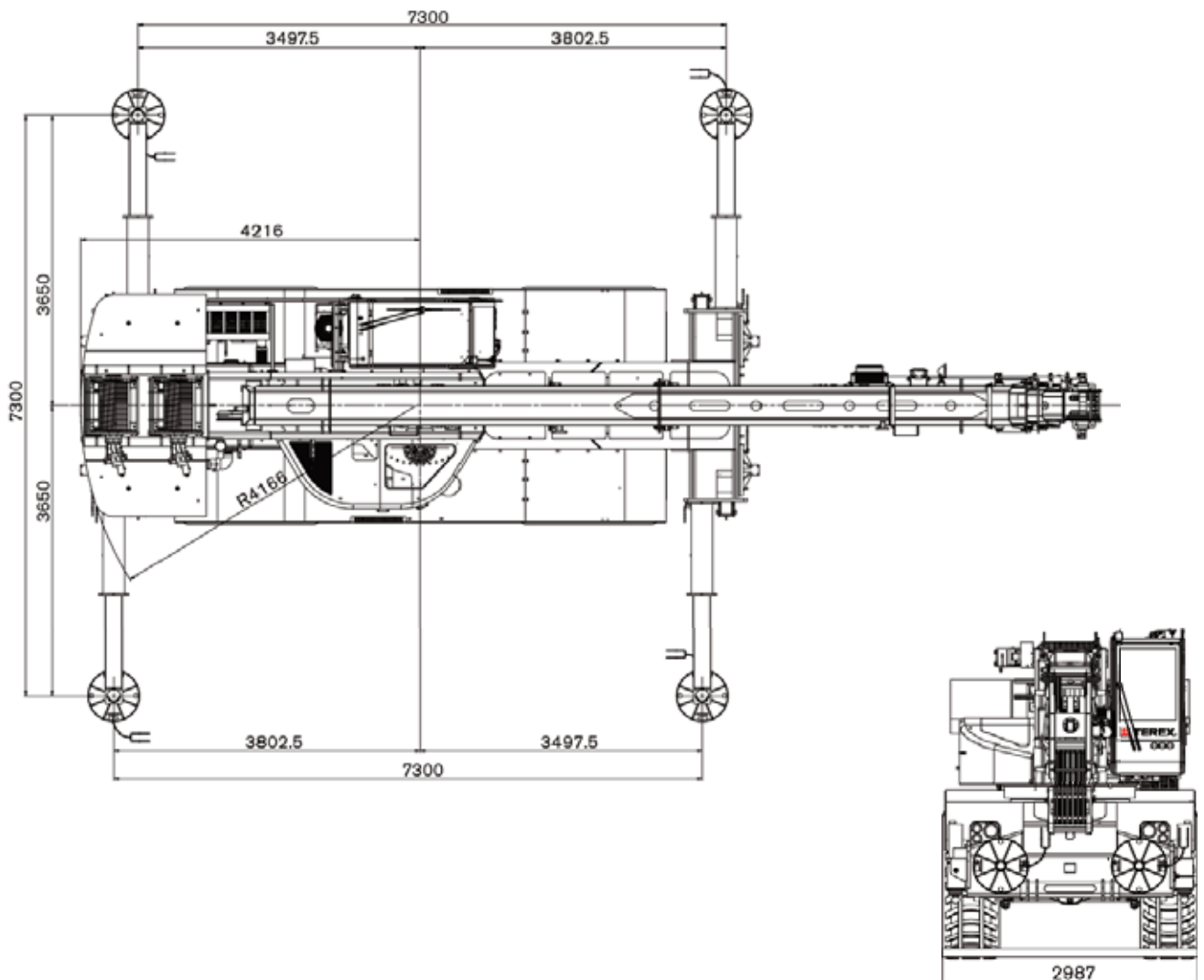

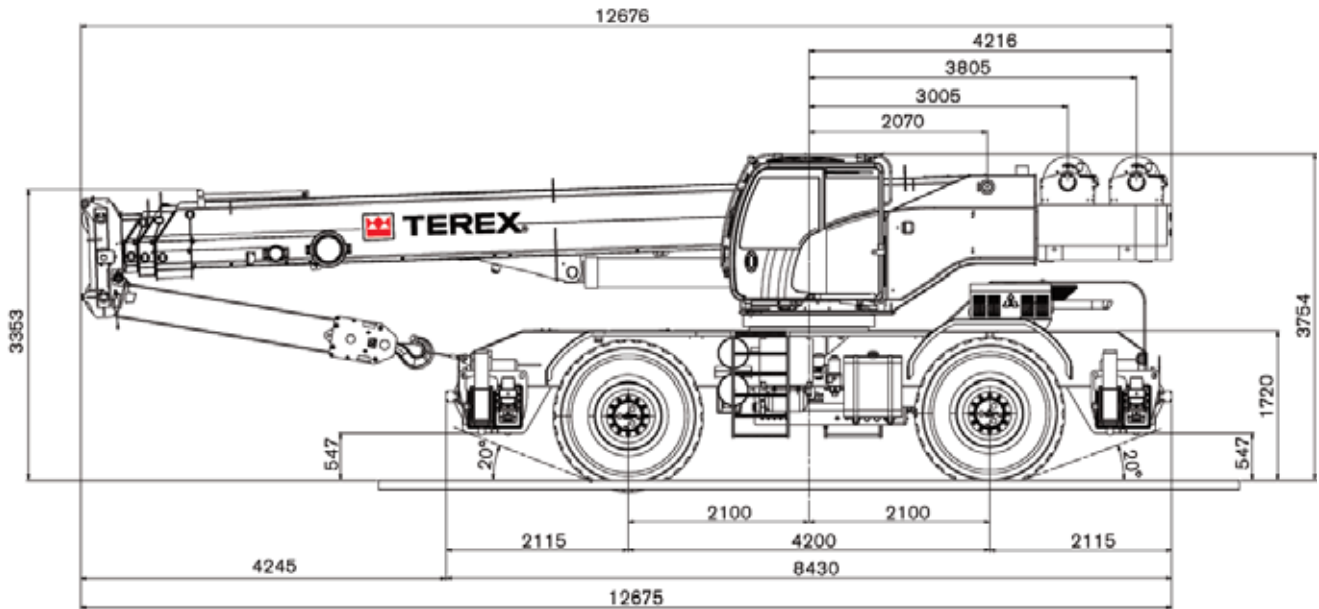





DIMENSIONS · ABMESSUNGEN · DIMENSIONI · DIMENSIONES ·
DIMENSÕES · PAЗMEPЫ

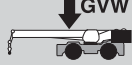
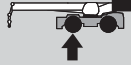
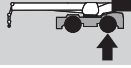
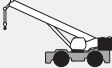

WEIGHTS

QUADSTAR 1065

POIDS · GEWICHTE · PESI · PESOS · PESOS · BEC

				
	without hook block · sans crochet moufle · ohne Unterflasche · senza bozello · sin gancho · sem moitão · п/ Крюкоблок	41 400 kg	18 100 kg	23 300 kg
Add / Subtract for main optional equipment · Supplément / retrait de poids pour équipement optionnel · Für optionale Ausstattung hinzufügen / abziehen · Da sommare a seconda dell'allestimento opzionale · Sumar / restar para equipamiento opcional principal · Acrescentar / subtrair para principais equipamentos opcionais · Добавить/вычесть для дополнительного оборудования				
	8 m stowed aside the boom · escamotable sur le côté de la flèche · seitlich am Ausleger verstaut · staffata a lato braccio · almacenado lateralmente a la pluma · guardada na lateral da lança · складываемая сбоку на главной стреле	+ 580 kg	+ 1022 kg	- 442 kg
	2 **	+ 830 kg	- 997 kg	+ 167 kg
	60 t*	+ 610 kg	+ 1065 kg	- 455 kg
	60 t*	+ 605 kg	+ 1056 kg	- 451 kg
	40 t*	+ 400 kg	+ 698 kg	- 298 kg
	12.5 t*	+ 255 kg	+ 455 kg	- 190 kg
	8 t*	+ 167 kg	+ 292 kg	- 125 kg

NOTE: Values are subject to 2% variation · REMARQUE : Les valeurs sont sujettes à une variation de 2% · HINWEIS: Werte können bis zu 2% abweichen ·
NOTA: I valori possono variare fino al 2% · NOTA: Valores sujetos a una variación del 2% · OBSERVAÇÃO: Valores sujeitos a 2% de variação ·
ПРИМЕЧАНИЕ. Значения даны с допуском +/- 2%

* Weight distribution calculated considering the hook block linked to the front shield of the machine · Répartition du poids calculée en considérant le crochet moufle connecté au panneau frontal de la machine · Berechnung der Gewichtsverteilung mit Hakenflasche am vorderen Rammschutz des Krans gesichert · Le distribuzioni dei pesi sono calcolate considerando il bozello legato davanti al carro · Distribución de pesos calculada considerando el gancho asegurado al protector frontal · Distribuição de pesos calculada considerando o moitão ligado à proteção dianteira da máquina · Распределение нагрузки рассчитано для крана с крюкоблоком, закрепленном на переднем щите машины

** Weight includes rope · Le poids comprend le câble · Gewicht einschließlich Seile · I pesi includono la fune · El peso incluye soporte cabrestante · Peso inclui cabo · Вес включает вес троса